

Original Instructions

# Installation, Operation & Maintenance Manual

## Sentry RX Sampler Point Samplers

S-SP-IOM-00293-4 11-17



COMPANY WITH  
QUALITY SYSTEM  
CERTIFIED BY DNV GL  
= ISO 9001 =

 **SENTRY**

# Table of Contents

Safety Information .....	4
General Safety Precautions .....	5
General Description .....	4
Installation.....	5
Operation.....	6
Maintenance.....	7
Troubleshooting .....	9
Standard Warranty .....	10
Customer Support.....	11



Do not install, maintain, or operate this equipment without reading, understanding, and following the appropriate Sentry Equipment Corp instructions. Otherwise, injury, damage, or both may result.

## Copyright

© 2017 by Sentry Equipment Corp. All rights reserved. All product and company names are property of their respective owners. This document contains proprietary information. No part of this document may be photocopied or reproduced without the prior written consent of Sentry Equipment Corp.

## Limit of Liability

Sentry Equipment Corp, its employees, agents, and the authors and contributors to this document specifically disclaim all liabilities and warranties, express or implied (including warranties of merchantability and fitness for a particular purpose), for the accuracy, currency, completeness, and/or reliability of the information contained herein and/or for the fitness for any particular use and/or for the performance of any material and/or equipment selected in whole or part with the user of/or in reliance upon information contained herein. Selection of materials and/or equipment is at the sole risk of the user of this publication.

## Note

The information contained in this document is subject to change without notice.

# Safety Information

Please read the entire manual before attempting to unpack, set up, or operate this product. Pay careful attention to all Warnings, Cautions, and Notes. Failure to do so could result in serious personal injury and/or equipment damage.

## Use of Hazard Information

If multiple hazards exist, the signal word corresponding to the greatest hazard shall be used.

## Definitions

### **DANGER**

**DANGER** indicates a hazardous situation which, if not avoided, will result in death or serious injury.

### **WARNING**

**WARNING** indicates a hazardous situation which, if not avoided, could result in death or serious injury.

### **CAUTION**

**CAUTION**, used with the safety alert symbol, indicates a hazardous situation which, if not avoided, could result in minor or moderate injury.

### **NOTICE**

**NOTICE** is used to address practices not related to personal injury.

### **NOTE**

Information that requires special emphasis.

### **TIP**

Alternate techniques or clarifying information.

**SHALL:** This word is understood to be mandatory.

**SHOULD:** This word is understood to be advisory.

# General Safety Precautions

## Product Selection, Installation, and Use

### WARNING

Improper selection, installation, or use can cause personal injury or property damage. It is solely the responsibility of users, through their own analysis and testing, to select products suitable for their specific application requirements, ensure they are properly maintained, and limit their use to their intended purpose.

Follow proper local, state, and federal regulations for proper installation and operational requirements.

Always use caution and common sense when working with any chemical. Read the product label and Material Safety Data Sheets (MSDS) carefully and follow the instructions exactly.

## Potential Equipment Hazards

### WARNING

**Hot surfaces!** This equipment may have very hot surfaces. If an operator contacts a hot surface, injury may occur. Use protective clothing to prevent injury. If other equipment comes in contact with a hot surface, damage to the equipment may occur. Ensure the area around this equipment is kept clear to prevent damage from occurring.

**High pressures!** This equipment may contain fluids at very high pressures. Prior to installing, removing or maintaining this equipment, ensure that the equipment is isolated from all connecting piping, the equipment is depressurized, the contents have been drained, and the equipment is cool.

**Moving parts!** This equipment may contain moving parts. All drive guards and doors must be secured in place when this machine is being operated.

## General Description

The Sentry® RX automatic strip sampler samples dry material from positive or negative, horizontal or vertical air conveying systems.

A sample is taken when a solenoid-controlled air cylinder or an electric-driven actuator moves a sample tube in and out of the product stream. Pressure between the conveying line and the sample container is equalized, allowing the sample to fall to the sample container. Since the sample outlet connection of the RX sampler moves as the sample tube is moved in and out of the product stream, the sample collection container is mounted separate from the sampler and is connected via a flexible hose to the sampler.

Product characteristics are not changed by the sampler because no moving parts convey the product to the sample container. Sample size and frequency can be changed at the controller.

### WARNING

Read these instructions completely before proceeding to assemble, install or operate this machine. This machine should be installed, operated and serviced by qualified individuals. All drive guards and doors must be secured in place when this machine is being operated. Follow proper local, state and federal regulations for proper installation and operational requirements.

# Installation

## ⚠ CAUTION

Sampler must be supported in two planes to prevent bending of the sample tube and to prevent personal and property damage.

1. Choose a location for the sampler. Product should be evenly dispersed in the material line. Make sure that the mounting location is six to eight feet beyond all elbows or line irregularities.
2. Mount the sampler to the line. Make sure the sample tube slot faces the flow of material so the sample can enter into the tube. The product discharge must face down.

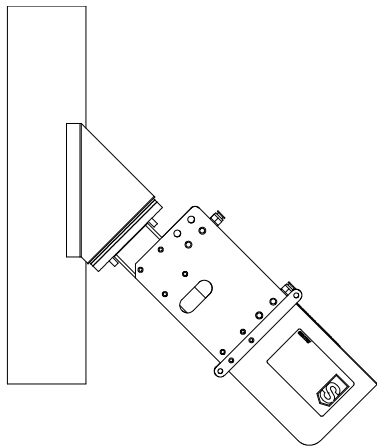
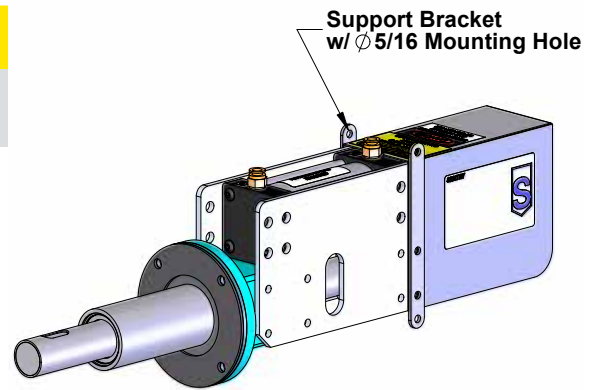

VERTICAL CONVEYING LINE

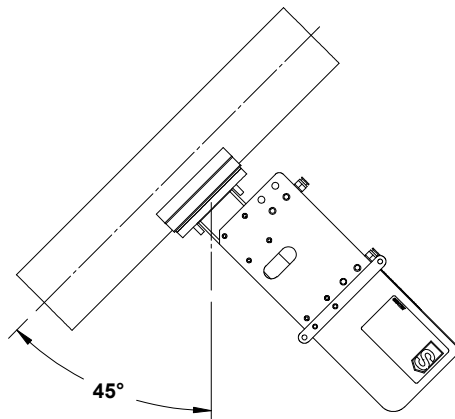

ANGULAR CONVEYING LINE

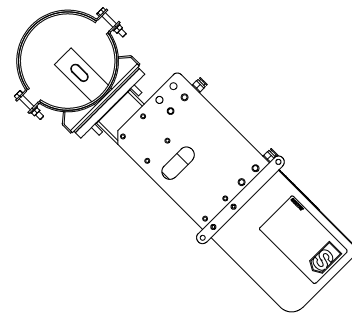

HORIZONTAL CONVEYING LINE

3. If the sampler is premounted at the factory:
  - a. Remove a section of the conveying line equal to the length of pipe in which the sampler is mounted.
  - b. Insert the sample tube facing into the product flow.
  - c. Clamp or bolt sampler in position. See drawing included with this manual for additional details.
4. If any side of your chute or line is less than 5 in, use a transition section to enlarge the line at the point of installation. The shortest Sentry RX sample tube is 4 in.
5. If the sampler comes with mounting adapters:
  - a. Cut a 2 in diameter hole in the conveying line to accommodate the sample tube.
  - b. Mount adapter wraps on the conveying line, making sure the hole in the adapter lines up with the hole in the conveying line. Then secure with the bolts.
  - c. Mount and fasten the sampler to mounting adapters with included hardware.
6. If the sampler is to be mounted to a chute that is 14 gauge or lighter, reinforce the chute with heavier gauge metal before bolting the sampler directly to the chute.
7. For samplers with chevron seals, the packing nut must be hand tightened using the included spanner wrench before the unit is started. Instructions are found in the Maintenance section of this manual.
8. Mount the sample bottle assembly. It may be mounted in any convenient location below the sampler. Best results are obtained when, in the sampling position, the discharge of the sampler is in direct line with the intake of the sample bottle.

9. Connect a flexible hose from the sample discharge to the sample collection container. In certain applications, rigid metal tubing can be used following a short length of hose attached to the discharge.
10. Mount the filter-regulator and the solenoid-valve. The bowl should be in a vertical position as close as possible to the sampler (see figure, right). Air pressure of 60 to 80 psi normally is recommended (3.9 to 5.6 kilograms per square centimeter). The regulator and the restrictors are preset at the factory. Air usage is 5 cubic inch per inch of stroke. CFM depends on how often the sampler is actuated.
11. Connect the lines from the solenoid-valve marked C1 and C2 to the corresponding C1 and C2 marks on the air cylinders with 3/8 in OD poly tube. (See figure, right. C1=Retract; C2=Extend).
12. Connect a clean air supply to the inlet of the filter-regulator. Oil and moisture filters should be used before the filter-regulator, if necessary. If an air lubricant is added to the system, it should be placed immediately after the filter-regulator. Air lines should not be so long that sharp bends or kinks develop in the lines. If an air purge is supplied, connect a purge gas source to the solenoid valve mounted on the sampler purge connection.
13. For the RX electric, connect the motor actuator leads to the controller using appropriate weatherproof cable or wire and conduit. See the wiring diagram included with this manual.

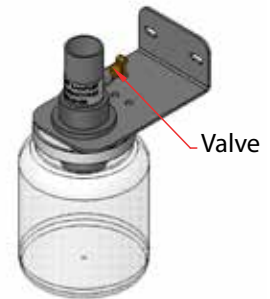
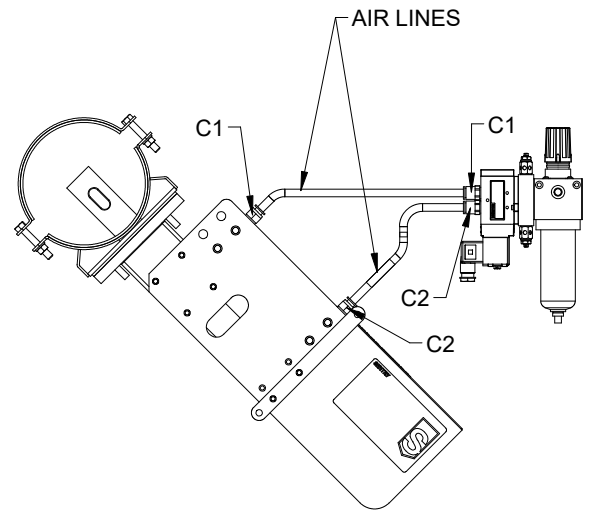

## Operation

### Sample Bottle Assembly

The valve on the sample bottle assembly is used to release pressure in the container. The valve may be opened a one-quarter turn to allow pressure to bleed slowly between sampling cycles. The valve must be closed when sampling on a vacuum line.

#### **⚠ WARNING**

Open the valve on the sample bottle assembly to release the container pressure before removing the container. **DO NOT** open the valve by more than a quarter turn during sampling. Fine material may escape, biasing the sample and possibly causing personal injury.

### Sample Probe Speed

The speed with which the sample probe extends and retracts can be increased or decreased by turning the flow controls on the four-way valve. Each screw regulates the air exhausting from the cylinder. Turn the screw clockwise to decrease cylinder speed. When shipped from the factory, the advancing and retracting speeds are equal.

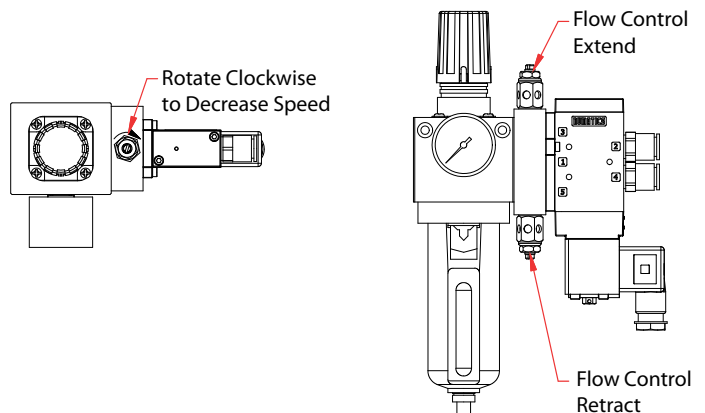

#### **↻ NOTE:**

If you make an adjustment to the four-way valve, you may need to adjust the timers in the controller.

# Maintenance

## ⚠ WARNING

Do not attempt to loosen or start disassembly of the sampler while the process line and pneumatic air cylinder are pressurized. All lines must be depressurized before any work can be done.

## Frequency

Because the Sentry RX sampler can be used with a wide variety of products and installations, there are no definite guidelines on how often maintenance should be performed. Maintain the sampler very closely for the first three to four months from initial installation and document wear vs. usage. Using this information, determine a maintenance program that fits your specific environment.

## Filter Regulator

Drain the filter/regulator at least once a week by turning the thumb screw on the bottom of the bowl. Draining frequency depends upon the quality of the air supply and may be required daily.

### ↻ NOTE:

**If an air lubricant is added to the system, it should be placed immediately after the filter regulator.**

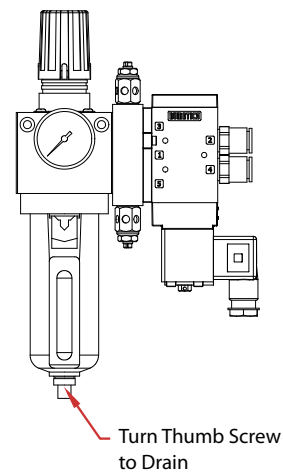

Excessive pressure drops or a visible coating on the filter element indicate cleaning of the filter regulator is necessary.

1. Shut off the air supply and remove the bowl.
2. Unscrew the lower gasket, allowing the filter element to fall out.
3. Wash the filter element with denatured alcohol.

## NOTICE

Use an alkaline solution (soapy water) and not a solvent for cleaning the polycarbonate bowl.

4. Clean the polycarbonate bowl with soapy water.
5. Reassemble the regulator and turn on the air supply.
6. Wash and blow out restrictors once a month or more frequently if necessary.
7. Replaceable items for the filter-regulator are the filter, bowl and gauge.

## Seal Adjustment

### Energized Seals

Standard samplers are supplied with maintenance-free energized seals. However, once the seals become worn they do need to be replaced.

### Chevron Seals

Samplers that are supplied with chevron seals require periodic maintenance.

## ⚠ CAUTION

Make sure that chevron seals are properly packed in order to prevent premature failure of the sampler. Tighten packing nut while the sample tube is being stroked out of the housing. Use caution to avoid injury.

When the seals are properly packed, the sample tube should stroke smoothly at 80 psi input pressure but show evidence of labor. If the sample tube stroke is rough, then the seals are packed too tightly. If the sample tube seems to move effortlessly, then the seals are packed too loosely.

When maintaining or replacing chevron seals, always tighten the packing nut as the sample tube is being stroked out of the housing. After seals are replaced, turn the seal packing nut in hand tight first, and then start stroking the sampler.

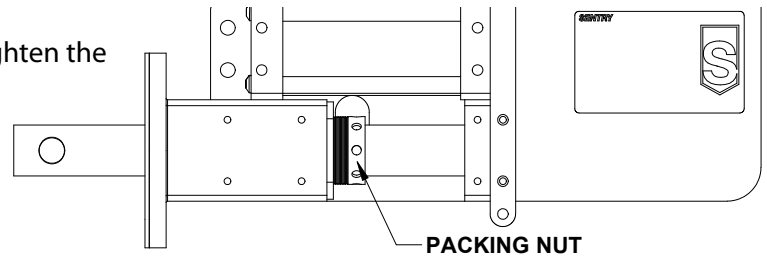

To adjust the seals:

1. Turn the packing nut clockwise a one-quarter to one-half revolution using the supplied spanner wrench. The packing nut should be hand tight.
2. Never loosen the packing nut more than a quarter turn at a time. Loosen only if the sample tube stroke is rough, indicating that the seals are packed too tightly.
3. Stroke the sampler three to four times, readjusting as needed.

During regular maintenance, the proper packing tightness should be achieved in three to four strokes of the sample tube. If the procedure takes much more effort than that, inspect the seals for excessive wear.

## NOTICE

Replace chevron seals once product has been introduced into the arrangement, as the seals will no longer work properly.

## Seal Replacement

If the seals become worn, you must remove and replace them. Loosen the drive arm from the tube.

1. Slide the tube from the sample housing out of the rear of the sampler.
2. Remove the packing plate and the retaining ring. For units with chevron spacers, remove the packing nut. For units with purge, remove the anti-rotation screw for the purge spacer.
3. Remove the seals and seal spacer. Discard the seals. Inspect the seal spacer and replace as needed.
4. Install new seals and the seal spacer. Note that the purge spacer has an anti-rotation slot. See figure, following page, for seal orientation.
5. Install the packing plate and retaining ring.
6. Slide the tube back into the housing from the rear and reinstall the drive arm removed in step 1.
7. For units with chevron seals, adjust according to the Seal Adjustment section in this manual.

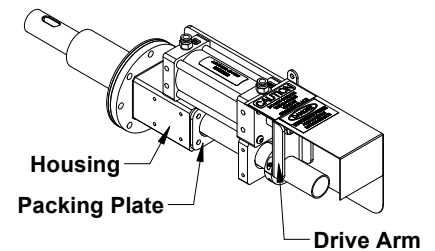
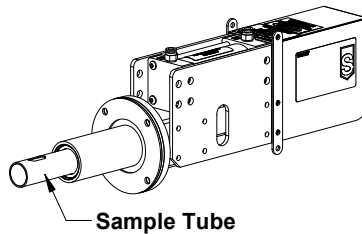

## NOTE:

Glass-filled Teflon seals will be slightly harder to slip the probe through, but once they are in, the probe will move freely.

## WARNING

Disconnect main power to controller before attempting any adjustments or disassembly.



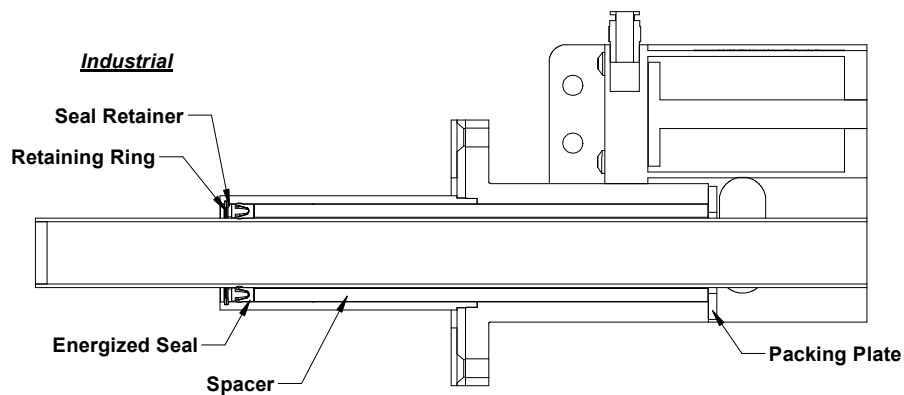
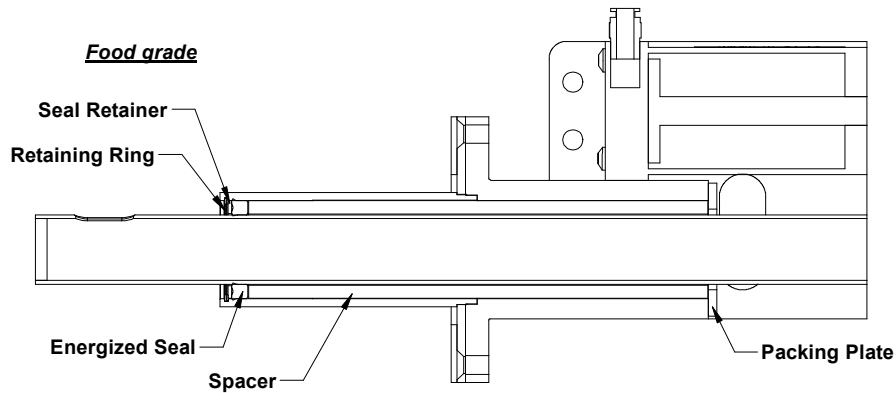
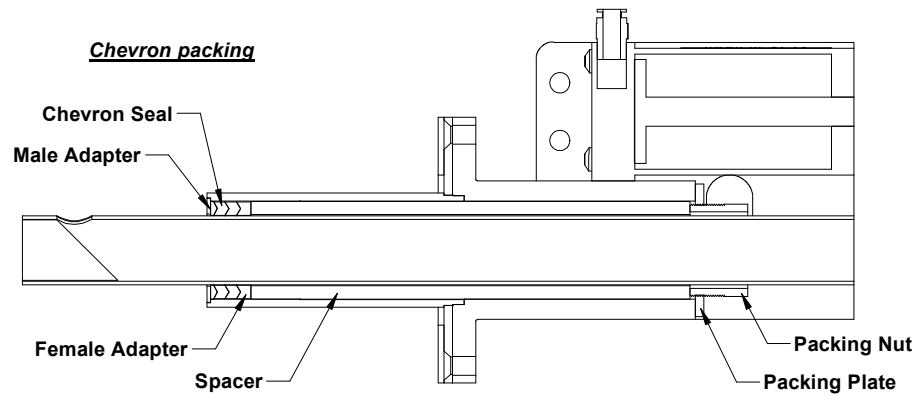

## Troubleshooting Sequence

1. Controller
2. Solenoid
3. Tubing kinks
4. Air pressure
5. Restrictors
6. Air cylinder
7. Packing
8. Alignment

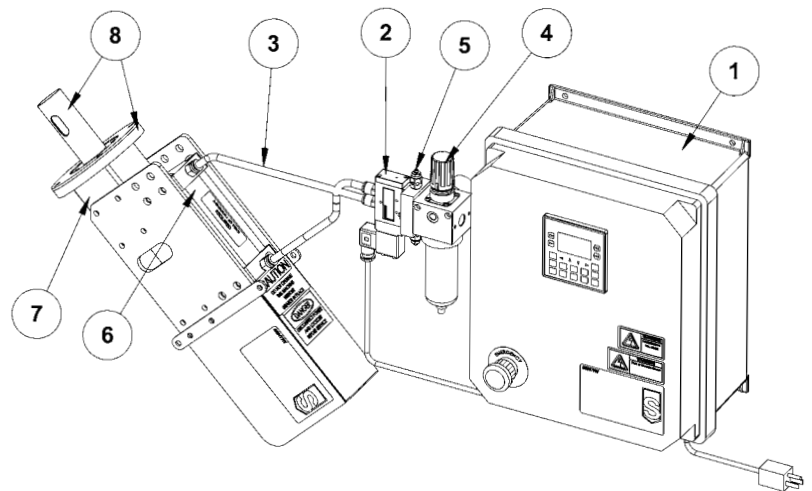

## Electrical

1. See controller manual.

## Pneumatic

- 2., 3., 4., 5. Check air lines for kinks, breaks, etc. Air pressure to the filter/regulator should be 60-80 psi. If higher air pressure is required to activate the cylinder, then it is possible that the probe is bound or the four-way valve needs cleaning. Look at the air restrictors and make sure they are open and not clogged.
6. If the probe slows up or stops when entering or retracting from the material line, the air cylinder seals may need replacing. If the main seal is worn, you may be able to hear air escaping around it.

## Mechanical

7. If the probe still does not function properly, check the seals for excessive wear or improper fit.
8. If the sampler properly runs mechanically, but still does not function correctly, then remove it from the line. Check for obstructions in the tube. Reassemble and check for operation. If any other problems arise, please contact Sentry Equipment.

# Standard Warranty

Sentry Equipment Corp (“Seller”) warrants products manufactured by it and supplied hereunder (“Products”) to be free from defects in workmanship and, to the extent materials are selected by Seller, to be free from defects in materials, in each case for a period as defined in the table below:

Product Line	Product Category	Warranty Period
Sentry®	1. Automatic Sampling 2. Corrosion Monitoring 3. Manual Sampling 4. Sample Conditioning 5. Sampling & Analysis Systems 6. Replacement Parts (without expiration dates)	Eighteen months from date of shipment or twelve months from startup, whichever occurs first
Waters Equipment	1. Sampling & Analysis Systems 2. Replacement Parts (without expiration dates)	Twelve months from date of shipment

To view the full warranty, go to [www.sentry-equip.com/warranty](http://www.sentry-equip.com/warranty).

# Customer Support

With proven sampling expertise since 1924, Sentry products and services provide business operations the critical insights to optimize process control and product quality. We deliver true representative sampling and analysis techniques to customers around the globe, empowering them to accurately monitor and measure processes for improved production efficiency, output, and safety. Standing behind our commitments, we are determined to tackle any application, anywhere.

We know that running an efficient operation isn't easy. It requires thorough, careful analysis of controlled, real-time data achieved through reliable, accurate, and repeatable process monitoring, and measuring. By effectively conditioning, sampling, and measuring gas, liquid, slurry, powder, solids, steam, or water within their production environments, our customers obtain the critical insights they need to control and optimize their processes.

Yet, controlling your processes also means reliable customer support throughout the life cycle of your equipment.

- Customer Service—General information, warranty claims, order management.
- Installation Service—For systems that require specialized expertise upon installation.
- Technical Support—Troubleshooting, training, and technical manuals.
- Field Service & Retrofits—When a problem needs immediate attention.
- Replacements Parts & Consumables—Order your replacement parts and consumables.
- Sentry ProShield Services – select from four ProShield Guardian service plans providing different levels of support to protect your large system investments with regularly scheduled maintenance.

To learn more, go to [www.sentry-equip.com/support](http://www.sentry-equip.com/support).

Serving customers  
in more than 50 countries  
across six continents worldwide.



[sentry-equip.com](http://sentry-equip.com)

966 Blue Ribbon Circle North, Oconomowoc, WI 53066 U.S.A. | +1-262-567-7256 | [support@sentry-equip.com](mailto:support@sentry-equip.com)