

Original Instructions

Installation, Operation & Maintenance Manual

Sentry IC Indexing Cabinet Automatic Sampling Accessories

S-AS-IOM-00462-2 11-17

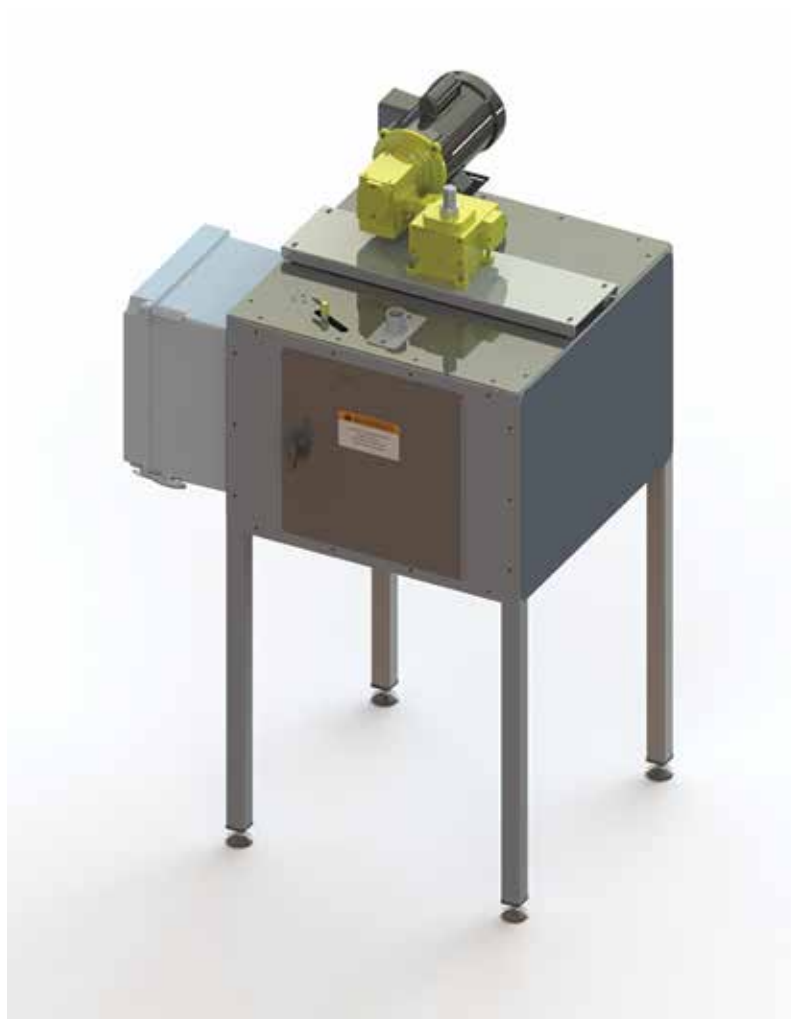

COMPANY WITH
QUALITY SYSTEM
CERTIFIED BY DNV GL
= ISO 9001 =

 **SENTRY**



Do not install, maintain, or operate this equipment without reading, understanding, and following the appropriate Sentry Equipment Corp instructions. Otherwise, injury, damage, or both may result.

Copyright

© 2017 by Sentry Equipment Corp. All rights reserved. All product and company names are property of their respective owners. This document contains proprietary information. No part of this document may be photocopied or reproduced without the prior written consent of Sentry Equipment Corp.

Limit of Liability

Sentry Equipment Corp, its employees, agents, and the authors and contributors to this document specifically disclaim all liabilities and warranties, express or implied (including warranties of merchantability and fitness for a particular purpose), for the accuracy, currency, completeness, and/or reliability of the information contained herein and/or for the fitness for any particular use and/or for the performance of any material and/or equipment selected in whole or part with the user of/or in reliance upon information contained herein. Selection of materials and/or equipment is at the sole risk of the user of this publication.

Note

The information contained in this document is subject to change without notice.

Table of Contents

- Safety Information4
- General Safety Precautions5
- General Description5
- Installation.....6
- Operation.....6
 - Sample Size6
 - Starting and Operating the Junction Box6
 - Emergency Stop.....6
 - Adjustments.....7
- Maintenance.....8
 - Potential Problems8
 - Troubleshooting Sequence8
- Standard Warranty9
- Customer Support.....10

Safety Information

Please read the entire manual before attempting to unpack, set up, or operate this product. Pay careful attention to all Warnings, Cautions, and Notes. Failure to do so could result in serious personal injury and/or equipment damage.

Use of Hazard Information

If multiple hazards exist, the signal word corresponding to the greatest hazard shall be used.

Definitions

DANGER

DANGER indicates a hazardous situation which, if not avoided, will result in death or serious injury.

WARNING

WARNING indicates a hazardous situation which, if not avoided, could result in death or serious injury.

CAUTION

CAUTION, used with the safety alert symbol, indicates a hazardous situation which, if not avoided, could result in minor or moderate injury.

NOTICE

NOTICE is used to address practices not related to personal injury.

NOTE

Information that requires special emphasis.

TIP

Alternate techniques or clarifying information.

SHALL: This word is understood to be mandatory.

SHOULD: This word is understood to be advisory.

General Safety Precautions

Product Selection, Installation, and Use

WARNING

Improper selection, installation, or use can cause personal injury or property damage. It is solely the responsibility of users, through their own analysis and testing, to select products suitable for their specific application requirements, ensure they are properly maintained, and limit their use to their intended purpose.

Follow proper local, state, and federal regulations for proper installation and operational requirements.

Always use caution and common sense when working with any chemical. Read the product label and Material Safety Data Sheets (MSDS) carefully and follow the instructions exactly.

Potential Equipment Hazards

WARNING

Hot surfaces! This equipment may have very hot surfaces. If an operator contacts a hot surface, injury may occur. Use protective clothing to prevent injury. If other equipment comes in contact with a hot surface, damage to the equipment may occur. Ensure the area around this equipment is kept clear to prevent damage from occurring.

High pressures! This equipment may contain fluids at very high pressures. Prior to installing, removing or maintaining this equipment, ensure that the equipment is isolated from all connecting piping, the equipment is depressurized, the contents have been drained, and the equipment is cool.

Moving parts! This equipment may contain moving parts. All drive guards and doors must be secured in place when this machine is being operated.

General Description

The Sentry® IC indexing cabinet is a rotating carousel for multiple sample containers. It is designed to collect all types of dry samples on a contamination-free basis and is compatible with the Sentry line of automatic solid and powder sampling solutions. It easily can be set up to collect either individual or composite samples. Standard systems are available in 8, 16 and 24 collection positions.

This indexing cabinet collection system can be controlled entirely by a standard PLC controller or interfaced with an existing Sentry sampler controller. An electric drive and capacitive brake system positively aligns the inlet with a collection container.

Self-adjusting inlet seals prevent cross-contamination as the system indexes from one container to another. The indexing cabinet collection system is available for non-hazardous and hazardous locations (Class II, Group G). It has a locking front door and door interlock sensor for operator safety.

WARNING

Read these instructions completely before proceeding to assemble, install or operate this machine. This machine should be installed, operated and serviced by qualified individuals. All drive guards and doors must be secured in place when this machine is being operated. Follow proper local, state and federal regulations for proper installation and operational requirements.

Installation

1. Choose a location for the IC indexing cabinet collection system(s) that is both convenient and as close to the sampler as possible. Level the unit by adjusting the feet.
2. Run a flexible hose from the sampler discharge to the inlet tube on the carousel. If the system must be more than 25 feet (7.6 meters) below the sampler, it may be advisable to install the collection hose in a zigzag pattern in order to prevent excessive velocity developing when the sample drops. The use of this configuration is dependent upon the product, needed in cases when the product is friable, subject to deformation, subject to segregation, or other conditions. In certain applications, rigid metal tubing can be used following a short length of hose attached to the sample discharge and/or inlet tube.
3. Mount the sampler controller in a vibration-free location and have a qualified electrician wire the sampler and the collection system to the controller.
4. Connect the motor leads and junction box to the sampler controller or PLC per the motor wiring diagram and electric wiring diagram supplied with this manual.

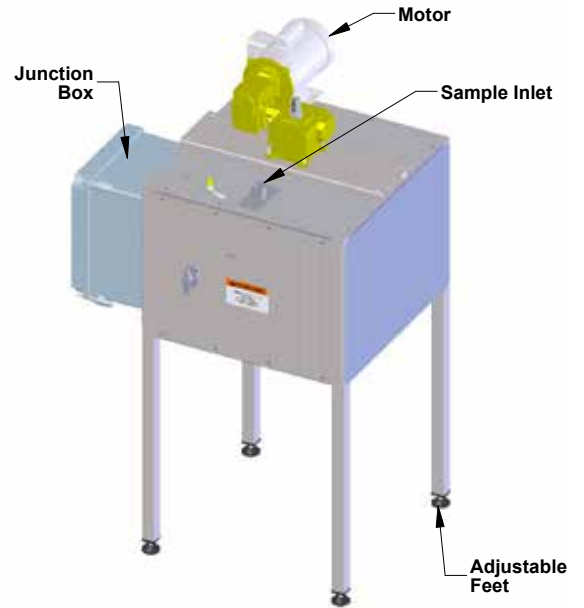

Operation

Sample Size

The amount of sample taken is related to the sampler setup, but should not exceed 3/4 of the container capacity. Exceeding 3/4 of the container capacity can cause choking in the line, and is not recommended. Verify containers are installed before sampling.

Starting and Operating the Junction Box

After installing the product in accordance with local codes and requirements, pull out the emergency stop button to power the IC indexing cabinet junction box. The junction box functions only with an external controller; see the Sentry SBC Sampler Controller manual and electric wiring diagram for additional electrical instructions.

The indexing cabinet can be advanced manually using the MANUAL INDEX push button on the front of the junction box. This push button only works if used with a Sentry SBC Sampler Controller or if the end users' control system has programmed it to operate.

Emergency Stop

The EMERGENCY STOP push button will remove power from the motor circuit.

⚠ WARNING

Disconnect the power to the sampler controller before opening and/or servicing. Live power is still in the box after the EMERGENCY STOP button is pushed.

Adjustments

Seal Tension Adjustment

1. Disconnect power from the unit and open the access door to reveal the t-handle adjustment on the spindle.
2. Loosen the locking collar on the t-handle.
3. Adjust the carousel height until the inlet bushings just touch the top plate, and then give the t-handle an extra one full turn to preload the bushings with spring tension.
4. Retighten the locking collar.
5. Verify that the position-sensor/carousel gap is 1/16-1/8 inch (see adjustment procedure below).

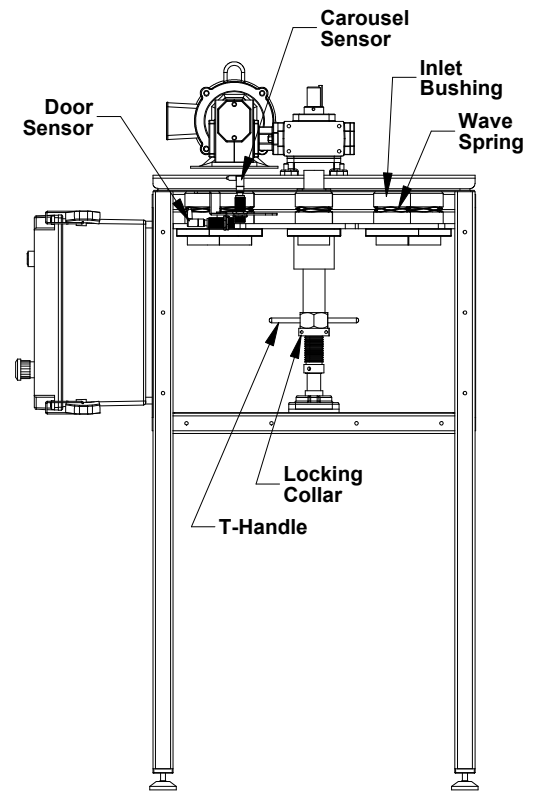

Sensor Adjustment – Carousel Stopping Position

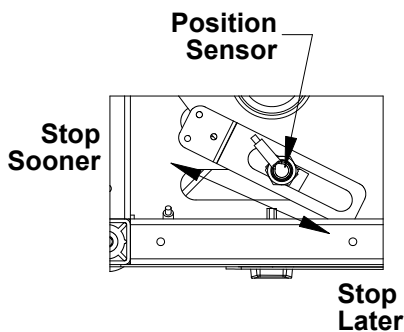

- Carousel rotates counter-clockwise when viewed from the top.
 - Verify inlet bushing adjustments before readjusting the stopping position.
1. Disconnect the power from the unit and open the access door to reveal the position sensor located at the top of the unit.
 2. Loosen the sensor retaining nuts and adjust the position of the sensor along the brackets' slot (see below) and verify the gap between the sensor and carousel is 1/16-1/8 inch.

Sensor Adjustment – Door Interlock Sensor

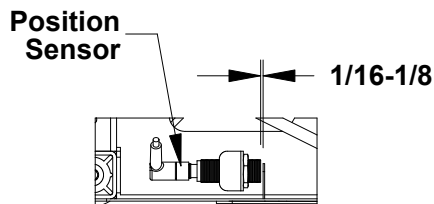

- The door interlock is set up to stop all activity if the door is not in the closed position.
1. Disconnect the power from the unit and open the access door to reveal the door interlock sensor located at the top left corner of the door opening.
 2. Loosen the sensor retaining nuts and adjust the position of the sensor to maintain a gap of 1/16-1/8 inch between the sensor and trigger tab (see below).
 3. Verify the sensor is functioning properly by powering up the unit, then verifying one of the PLC input lights turns on and off by opening and closing the door.

Maintenance

1. Check the seal tension between the inlet bushing and the top plate on a monthly basis. If adjustments are needed, see the Adjustments section of this manual for details.
2. The Gear-Reducer:
 - a. Check fluid level on a monthly basis.
 - b. Initial fluid change should occur at 250 hours of operation.
 - c. Subsequent fluid changes occur every 2500 hours of operation.
 - d. Consult the Gear-Reducer documentation provided at purchase for fluid specifications.
 - e. All other adjustments are on an as-needed basis.

Troubleshooting

The following information is a synopsis of the problems you may encounter prior to troubleshooting your equipment. Divide the unit into three sections and try solving the problem before you continue on.

Potential Problems

Electrical

- Controller/Junction box
- Connections
- Circuit breaker
- Proximity switches
- Motor

Mechanical

- Carousel binding
- Gear reducer
- Jar alignment

WARNING

Disconnect main power to controller before attempting any adjustments or disassembly.

Troubleshooting Sequence

1. Controller
2. Carousel/Proximity sensors

Electrical

1. See controller manual.

Mechanical

2. Carousel/Proximity Sensors
 - a. Check connections to the motor and sampler controller to ensure that the carousel is rotating in the correct direction. Remove the sample inlet and observe the direction of the carousel. Correct wiring as necessary.
 - b. Check to see if any sample material is packed or stuck in the inlet due to an obstruction. Set up a regular cleaning schedule for the sampler based on sampled material properties. Reinstall the sample inlet.
3. Other troubleshooting steps:
 - a. Carousel will not move
 - Door is not closed
 - Door proximity switch is not adjusted correctly and functioning
 - Check for power to the control box

- Circuit breaker
- Signal to index not present
- b.** Carousel won't stop moving
 - Carousel proximity switch is not adjusted correctly and functioning
- c.** Carousel doesn't stop in the correct location
 - Carousel proximity switch is not adjusted correctly and functioning
 - Carousel is not adjusted up against the top properly
- d.** Sample leaks inside the cabinet
 - Carousel is not adjusted up against the top properly

Standard Warranty

Sentry Equipment Corp ("Seller") warrants products manufactured by it and supplied hereunder ("Products") to be free from defects in workmanship and, to the extent materials are selected by Seller, to be free from defects in materials, in each case for a period as defined in the table below:

Product Line	Product Category	Warranty Period
Sentry®	1. Automatic Sampling 2. Corrosion Monitoring 3. Manual Sampling 4. Sample Conditioning 5. Sampling & Analysis Systems 6. Replacement Parts (without expiration dates)	Eighteen months from date of shipment or twelve months from startup, whichever occurs first
Waters Equipment	1. Sampling & Analysis Systems 2. Replacement Parts (without expiration dates)	Twelve months from date of shipment

To view the full warranty, go to www.sentry-equip.com/warranty.

Customer Support

With proven sampling expertise since 1924, Sentry products and services provide business operations the critical insights to optimize process control and product quality. We deliver true representative sampling and analysis techniques to customers around the globe, empowering them to accurately monitor and measure processes for improved production efficiency, output, and safety. Standing behind our commitments, we are determined to tackle any application, anywhere.

We know that running an efficient operation isn't easy. It requires thorough, careful analysis of controlled, real-time data achieved through reliable, accurate, and repeatable process monitoring, and measuring. By effectively conditioning, sampling, and measuring gas, liquid, slurry, powder, solids, steam, or water within their production environments, our customers obtain the critical insights they need to control and optimize their processes.

Yet, controlling your processes also means reliable customer support throughout the life cycle of your equipment.

- Customer Service—General information, warranty claims, order management.
- Installation Service—For systems that require specialized expertise upon installation.
- Technical Support—Troubleshooting, training, and technical manuals.
- Field Service & Retrofits—When a problem needs immediate attention.
- Replacements Parts & Consumables—Order your replacement parts and consumables.
- Sentry ProShield Services – select from four ProShield Guardian service plans providing different levels of support to protect your large system investments with regularly scheduled maintenance.

To learn more, go to www.sentry-equip.com/support.

This page is intentionally left blank.

Serving customers
in more than 50 countries
across six continents worldwide.



sentry-equip.com

966 Blue Ribbon Circle North, Oconomowoc, WI 53066 U.S.A. | +1-262-567-7256 | support@sentry-equip.com