

SENTRY DS-3 SAMPLER

Point Samplers

AUTOMATIC SAMPLING

The Sentry® DS-3 sampler is a heavy-duty point sampler that automates sampling of materials such as grains from conveyors. A point sampler captures samples from a point in a process stream and often is used when the material is homogenous.

With an overall height of less than 24 inches (61 cm), the low profile Sentry DS-3 sampler mounts at any convenient point along a conveyor and allows for installation in areas with low headroom. The sampler arm and drive components are mounted within a steel enclosure. To obtain a sample, the scoop rotates through a conic sweep path, scooping a sample from the belt, which is then pitched and poured into a large stainless steel hopper that discharges to the side of the belt.

MODELS

DS-3

BENEFITS

With representative sampling, characteristics of each sample match that of the entire lot or batch—so samples are repeatable, leading to accurate sample analysis data. Automatic sampling ensures a sample can be easily and safely obtained with no need for direct human interface or interference. This ensures sample integrity as well as operator safety.

The Sentry DS-3 sampler mounts using heavy, bridge-type supports. The sampler controller and discharge can be assembled to accommodate access from the right or left side of the conveyor. Arm speed is adjustable to suit belt speeds up to 900 FPM. The arm moves at a slightly faster speed in the same direction as the conveyor belt, collecting a sample without disrupting material.

The arm drive system is a rugged worm gear reducer in combination with a variable speed motor drive, which produces a wide range of flexibility in matching arm speed to the speed of the conveyor belt. Cycle rates are adjustable to sample at a maximum frequency of twice per minute.

FEATURES

- Heavy-duty frame and drive components
- Hinged inspection doors interlock to prevent arm rotation if open
- Precycle warning signals for operator safety
- Standard scoop is approximately 3 inches (76 mm) wide and will hold 12 in³ to 16 in³ (196 to 262 cc) of sample each cycle; optional 4 inch (102 mm) wide scoop and smaller sample cutters available
- NEMA 4 enclosure for sampler controller for dust and weather protection
- Options include enclosed sample container platforms for moisture and fines retention; explosion-proof option with electrical components suitable for use in Class I Div 1 Group D, or Class II Div 1 Group G & F hazard-rated areas; open-style sample container platform with 10-gallon metal containers



Sample. Monitor. Measure.

SENTRY

Any Application. Anywhere.

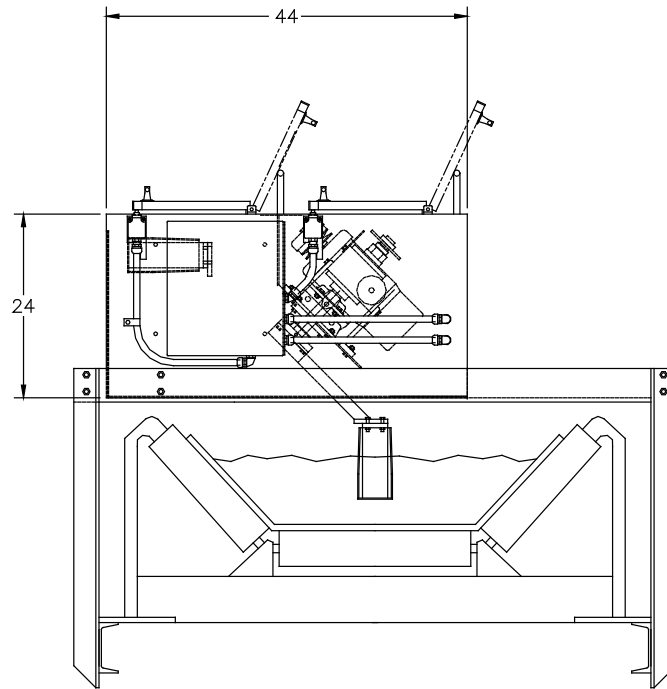

SPECIFICATIONS

materials	painting carbon steel enclosure with 300 stainless steel hopper
sample volume per cycle	up to 16 in ³ (262 cc)
particle size	2 in (50 mm)
maximum belt speed	to 900 FPM, adjustable
maximum cycle rate	twice per minute
electrical requirements for sampler controller	230/460 VAC, three-phase, 50 or 60 Hz
shipping weight	900 lb (409 kg)

sentry-equip.com

966 Blue Ribbon Circle North, Oconomowoc, WI 53066 U.S.A. | +1-262-567-7256 | sales@sentry-equip.com

© 2016 Sentry Equipment Corp. All rights reserved. All product and company names are property of their respective owners. It is solely the responsibility of end users, through their own testing and analysis, to select products and materials suitable for their specific application requirements, ensure they are properly installed, safely applied and properly maintained, and to limit their use to their intended purpose. Improper selection, installation or use may result in personal injury or property damage.

S-SP-SPS-00178-5 12-16



COMPANY WITH
QUALITY SYSTEM
CERTIFIED BY DNV GL
= ISO 9001 =