

Backed By
Over 80 Years of
Sampling Experience

SAMPLE CONDITIONING COMPONENTS

FOR STEAM & WATER

www.sentry-equip.com

COMPONENTS FOR PRECISE SAMPLE CONDITIONING

The essential elements of representative sampling are precise temperature, pressure and flow control — these are at the core of any good sampling system. Sentry Equipment manufactures the largest variety of sampling components available for water, steam and process sampling. Sentry also integrates these components into standard and custom sampling and analysis systems.

SAMPLE COOLERS

Heavy duty stainless steel construction, other materials available. Over 20 models to handle any application. ASME/CRN stamp available.

Ask for Bulletin 4.10

VREL® PRESSURE REDUCER

U.S. Pat. No. RE37,153

Reduce high pressures without valve wear. Cleanable in place. Adjustable while in service.

Ask for Bulletin 1.10.1

THERMAL SHUT-OFF VALVE

U.S. Pat. No. 5,826,790

Shuts down high temperature sample in less than 5 seconds. Protects analyzers and operators.

Ask for Bulletin 13.1.1

TEMPERATURE CONTROL UNIT

Maintain sample temperature at 77°F (25°C). Water or air cooled. Rugged design for power plant environment.

Application specific, contact Sentry

BACK PRESSURE REGULATOR/RELIEF VALVE

Maintain precise sample pressure to assure proper flow control. Factory set to eliminate unnecessary adjustment of setting. Built-in relief valve to protect analyzers.

Ask for Bulletin 9.1.1

CATION CONDUCTIVITY ACCESSORIES

Cation resin columns designed specifically for power plants. Complete panels to measure specific, cation, and degassed conductivity or any individual measurement. Custom analysis panels including degassed conductivity, DO, and corrosion product sampling.

Ask for Bulletins 6.1.1 (resin column) & 1.43.1 (degassed panel)

SAMPLE SEQUENCER™

Time share several streams with one analyzer. Operates with either batch type or continuous reading analyzers.

Ask for Bulletin 5.5.10

MANIFOLD VALVE

U.S. Pat. No. 5,469,751

No cross contamination. Continuous sample flow in all lines.

Ask for Bulletin 5.5.20

CORROSION PRODUCTS SAMPLER

Identify and quantify corrosion throughout the thermal cycle. Portable or panel mount versions available.

Ask for Bulletin 11.1



Sample Coolers

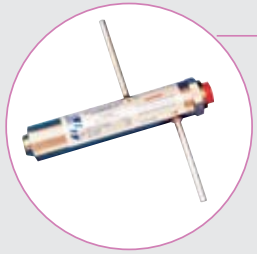

Thermal Shut-Off Valve



Temperature Control Unit



Back Pressure Regulator/Relief Valve

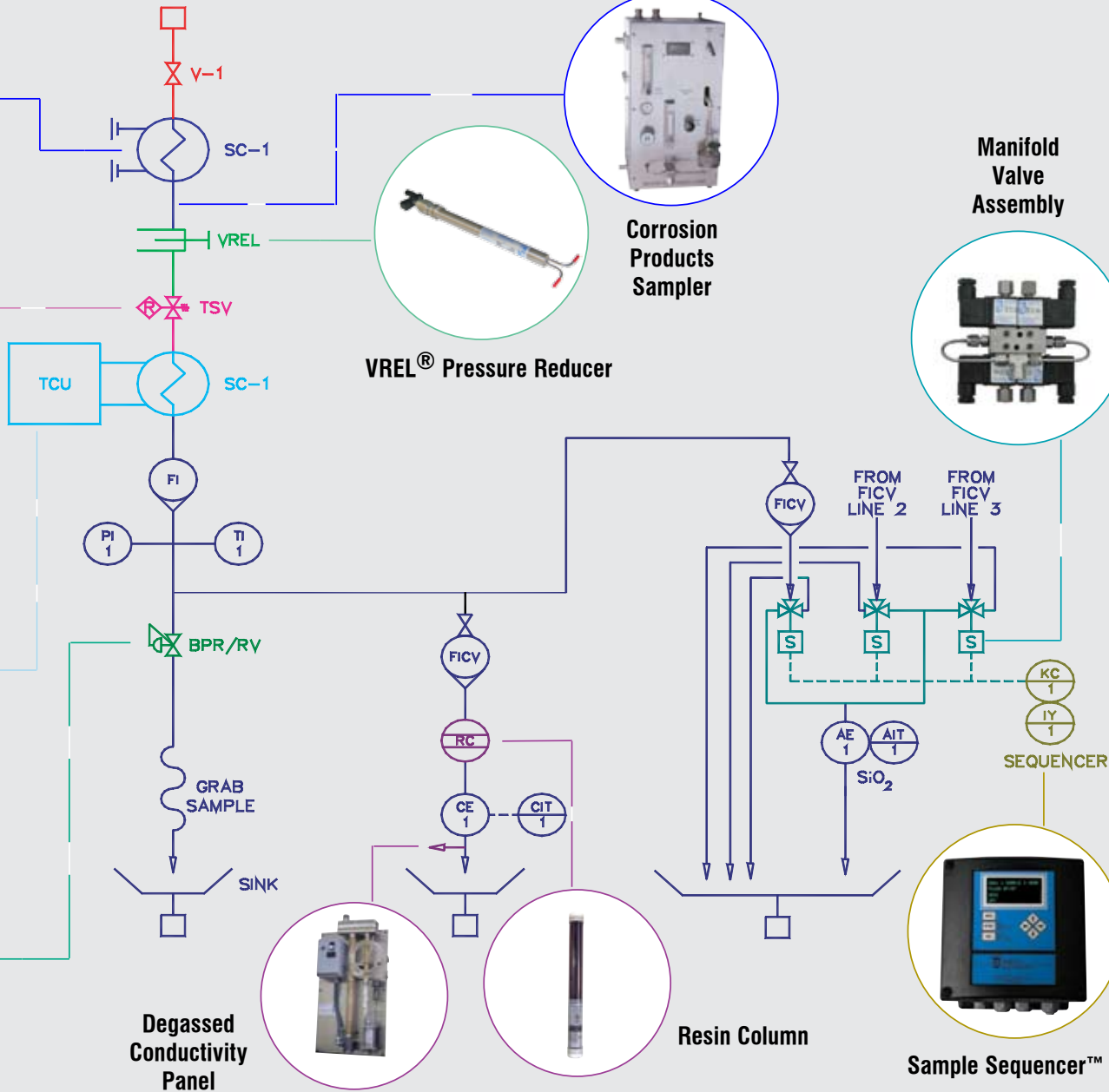

Corrosion Products Sampler

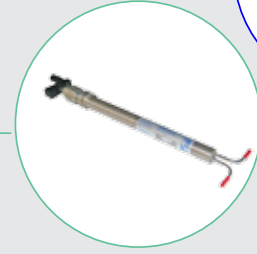

VREL[®] Pressure Reducer

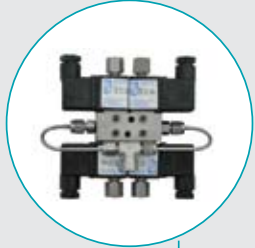

Manifold Valve Assembly



Sample Sequencer™

Resin Column

Degassed Conductivity Panel

To learn more about sample conditioning and to download referenced bulletins visit us at:

www.sentry-equip.com

CUSTOM SAMPLING SYSTEMS FOR DEMANDING SAMPLING REQUIREMENTS

Ask for Bulletin 1.2.1

- Sample Conditioning and Analysis Panels
- Primary and Secondary Sampling Systems – Nuclear
- Post Accident Sampling Systems – Nuclear
- Process Sampling Systems



FREE ON-SITE EVALUATION *of your existing sampling system*

Email: evaluation@sentry-equip.com
or call **262-560-8145**

PARTS & SERVICE

Replacement parts and field service are available for Sentry or any brand of sampling and analysis systems worldwide.

WARNING

It is solely the responsibility of the end-user, through its own analysis and testing, to select products and materials suitable for their specific application requirements, ensure they are properly installed, safely applied, properly maintained, and limit their use to their intended purpose. Improper selection, installation, or use may result in personal injury or property damage.



SENTRY EQUIPMENT CORP

PO Box 127
Oconomowoc, WI 53066 USA
Phone: 262-567-7256
Fax: 262-567-4523

E-mail:
sales@sentry-equip.com

Website:
www.sentry-equip.com

QUALITY MANAGEMENT SYSTEM
CERTIFIED BY DNV
ISO 9001:2008

For further information, contact: