



ISOLOK[®] SERIES SAL-B AUTOMATIC SAMPLER

U.S. Patent No. 6,792,818; 6,164,145; 5,905,213 • Canadian Patent 2,418,263

Integral ISOVALVE[®] Allows Removal from Pressurized Process Lines

Features

- Two different models for sampling fixed volumes of 8 cc or 25 cc per sample cycle
- Particles up to 3/8" (9 mm) major dimension can be sampled
- Can handle line pressures up to 300 psi
- ISOVALVE[®] enables sampler removal while process line remains in service

Options

- Optional "park position" cylinder allows sample plunger to dwell flush with nose end of sampler
- Port closures
- Several types of containers
- Sampler enclosures (with or without heater)
- Sample heating or refrigeration
- Optional materials of construction and seal choices

Description

Collection of accurate samples from continuously pressurized process lines can be readily accomplished with series SAL-B samplers. Each cycle collects a fixed displacement of liquid or slurry. The unique design integrates an ISOVALVE[®] ball valve into the two-piece body. When off-line inspection or maintenance is needed, the ISOVALVE[®] can be closed and the entire sampler removed while the process line remains in pressurized service.

Metal parts are 316 stainless steel, while tough, thru-hardened 17-4PH is used for the isolation ball. Optional construction includes other metal alloys and wear-resistant nickel tungsten carbide bushings through the body and valve bore.

Optional "park position" cylinder is available to allow sample plunger to dwell flush with the nose end of the sampler. This feature prevents any accumulation of process solids in open end of sample valve. Because plunger is extended flush to end of sampler, faster cycle times are also possible.

ISOLOK[®] samplers have a reputation for reliable service under tough job conditions. They can handle oil sand slurry sampling on a continuous basis, as well as sand and gravel tailings lines. The separate closure plate caps the valve when the sampler is off-line or also seals bolt hub if entire system is removed. Telltale ports on isolation valve allow pressure inspection before sampler is detached.

SAL-B samplers bolt-mount onto machined pads welded to process pipes. Flange mounting is also available, along with a full line of controls and accessories.

ISOLOK[®] SAL-B TECHNICAL DATA

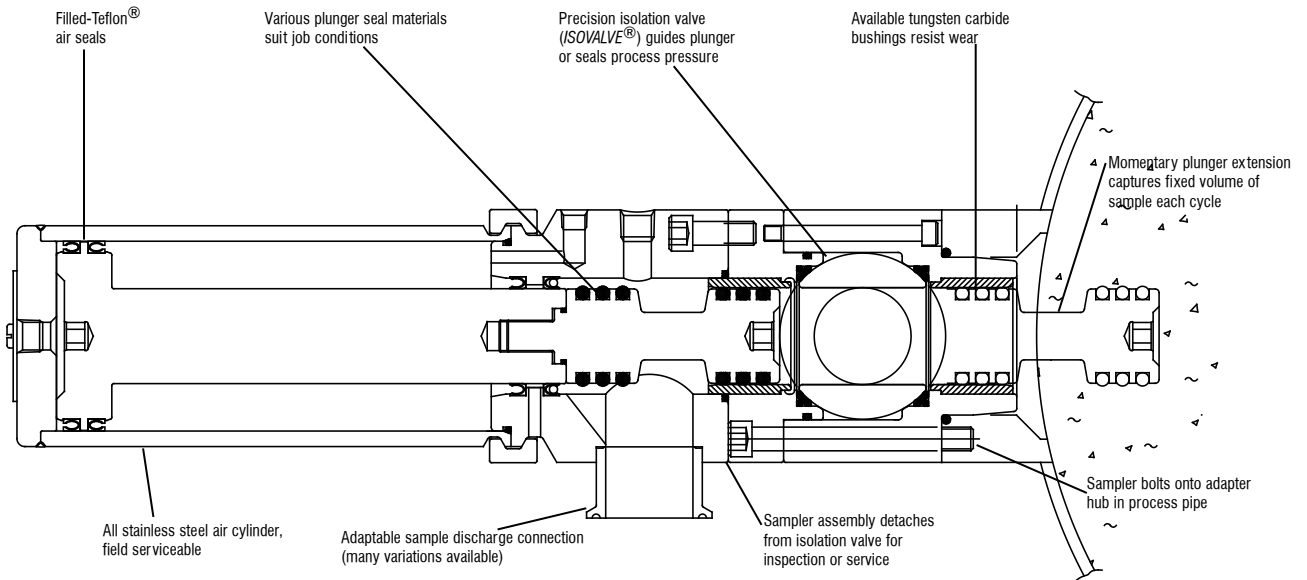

SPECIFICATIONS

Sample Volume per Cycle	8 cc (0.5 cu. in.) or 25 cc (1.5 cu. in.)
Maximum Particle Size	3/8" (9 mm)
Basic Electrical Requirements	115 VAC, single phase, 50/60 Hz
Line Mounting Options.	bolting hub pad ANSI or DIN flange
Compressed Air Requirements	60 psig minimum
Materials of Construction	316 and 17-4PH stainless steel
Actuator and Static Seals	Filled PTFE and fluoroelastomer
Plunger Seals	polyurethane, EPDM elastomer, Kalrez [®] , PTFE, NBR or VHMW
Overall Dimensions, length x diameter	15.875 in. (40 cm) x 6 in. (15.25 cm)
Net weight, not including controller or accessories	33 lbs. (15 kg)

⚠ WARNING

It is solely the responsibility of the end-user, through its own analysis and testing, to select products and materials suitable for their specific application requirements, ensure they are properly installed, safely applied, properly maintained, and limit their use to their intended purpose. Improper selection, installation, or use may result in personal injury or property damage.

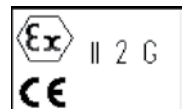

SENTRY EQUIPMENT CORP

PO Box 127
Oconomowoc, WI 53066 USA
Phone: 262-567-7256
Fax: 262-567-4523

E-mail:
sales@sentry-equip.com

Website:
www.sentry-equip.com

QUALITY MANAGEMENT SYSTEM
CERTIFIED BY DNV
ISO 9001:2008

For further information, contact: